

MODEL 2462 OPERATORS MANUAL

StraightLine Directional Drilling System

Manual Number 9020015



Manufacturer of Directional Drilling Equipment
WWW.STRAIGHTLINEHDD.COM

STRAIGHTLINE ®

1450 South Spencer Road - Newton, Kansas 67114 - 316-283-5511 - 800-654-3484 - Fax 316-283-2783

rev. 04.10.00

Glossary

Anchor

System of plates, stakes, and pins that secures the drill rack to the ground.

Backreamer

Tool used during pullback for enlarging pilot bore.

Bar

Measurement of pressure (metric).

Bentonite

Finely ground clay commonly mixed with water for drilling solution.

Bore Log

Drawing of the proposed bore path in plan view and side view showing entry, exit, depth, existing hazards, steering areas including curve radii, and other information.

Bore Path

Planned or actually traveled location of the drill head/string through the earth.

Breakout

Loosening a section of drill pipe prior to removing it from the drill string.

Breakout Wrenches

System of manually held or hydraulically powered friction wrenches for holding drill pipe from rotating when adding drill pipe. It is also used for loosening drill pipe joints when removing drill pipe.

Breakout Wrench

The rear most built-in drill pipe wrench which is hydraulically rotated and used when removing drill pipe sections when pulling back.

Carriage

Traveling unit which pushes and rotates the drill pipe.

Chocks

Wedges used to block wheels and tires so as to hold them into position.

Control Panel

Panel containing all gauges, hydraulic valves, switches and buttons required to operate the drill rack, and or power unit.

Cutting Teeth

Hardened cutting burrs, usually carbide, on drill heads and backreamers.

Down-Hole Equipment

Same as tooling.

Drive Chain

Large, heavy chain which drives carriage up and down drill rack.

Drill Head

Assembly of cutting bit, steering shoe, and transmitter housing.

Drill Pipe

Sections of high-strength steel pipe with threaded tool joints attached. Drill pipe is sized for length, diameter, and thread size for each model of Drill Rack.

Drill Rack

The mobile portion of the drilling system capable of rotating and pushing drill pipe into the soil.

Drilling Solution

The fluid mixture which is pumped out of the drill head to facilitate boring.

Drill String

Assembly of drill head and all attached drill pipe.

Equal Potential Mat:

Large metal mesh mat on which operators stand during operation to give grounding protection in case of an electrical hit.

Filter Sub

Device between the drill head and the drill pipe which contains a mesh strainer to prevent lumps of material in the drilling fluid from clogging fluid jets.

Feathering

To meter or regulate the speed of a function by precisely controlling the movement of the control lever.

GPM

Abbreviation of gallons per minute, a measure of liquid flow rate.

Ground Rod

Copper/Brass rod which is hand driven into the ground to give grounding protection in case of electrical hit.

Ground Rod/Mat Cables

Cables which attach drill rack main frame to equal potential mats and rod.

Jets

Replaceable fluid outlets found in both drill heads and backreamers.

Locate

1) The operation of using the locator to determine drill head position. 2) The identification of existing underground utilities and hazards done by the utility service company. 3) The hazards identified are commonly referred to as "Locates" and the process of marking the hazards is commonly referred to as "Doing locates".

Locator

1) The hand-held receiving portion of the radio detection equipment. 2) The person using the locator equipment.

Makeup

Adding a new section of drill pipe to the in-use drill string.

Makeup Wrench

The forward-most built-in drill pipe wrench on the drill rack used in both adding and removing drill pipe sections.

Mud Mixer

Gasoline engine, or hydraulic, powered recirculation pump which allows drilling fluid additives to be added and thoroughly mixed.

pH Scale

Index which indicates acidity of a liquid.

Pilot Bore

Process of guiding the drill string to a specific location, according to the planned bore path.

Pipe Guide

Tube mounted in front of the breakout wrenches to help guide the pipe throughout the bore. Includes a replaceable polyurethane insert to lengthen the life of the drill pipe.

Polymer

Chemical added to water or bentonite mixture used as drilling solution.

Pull Back

Operation of pulling the material being installed into the finished bore path, usually combined with the backreaming operation.

PSI

Abbreviation of pounds per square inch, a measure of pressure.

Pushing

Thrusting the drill string without rotation to change the direction of the pilot bore.

Returns

The loose material dislodged when boring or backreaming, usually mixed with drilling solution. Sometimes known as cuttings or spoils.

Rotation

Rotating the drill string to give a straight pilot bore.

Rotation Motor

Hydraulic motor located on the carriage which rotates the drill string.

Sonde

See Transmitter.

Stake

Headed steel pins which are driven into the ground through holes in anchor plates.

Steering Shoe

Replaceable shoe on the drill head, mounted at an angle which causes the drill string to veer when being pushed without being rotated.

Strike Alert

Alarm system which indicates the presence of electrical current in the drill string.

Sub saver

Replaceable connector through which the drill pipe is attached to the carriage.

Swivel

Device at the end of the drill string during backreaming/pullback operations which prevents material being installed from twisting.

Thrust

Force used in moving the carriage and drill string linearly, measured in pounds.

Thrust Motor

Hydraulic motor located at the back of the main frame which powers the chain that draws the carriage up or down the drill rack.

Tooling

Drill string, boring, backreaming, and pulling equipment.

Torque

Force used in rotating the drill string, measured in ft.-lbs.

Tracking

Marking the path of the drill head as it advances down the bore path.

Tramming

Using the tracks to move the drill rack.

Transmitter

Radio transmitting device which is placed inside drill head necessary for accurate locating.

Umbilical

Fluid hoses and Electrical cables connecting the drill rack to the trailer or mud skid.

Utility

1) The existing electrical, gas, water, etc. service at the bore site and the company that either owns or operates them as in: "Utility hit" or "Having the utility company do the 'Locates'". 2) The material which is being pulled into the backreamed, pilot bored tunnel, as in: "Installing or pulling the utility".

Viscosity

Measure of fluid thickness, measured in seconds. Sometimes expressed as weight.

Water Swivel

Fluid elbow at front of the carriage which connects the drilling fluid to the drill pipe.

Water Pump

Hydraulically driven high-pressure pump which pumps the drilling fluid.

Water Tank

Large reservoir which holds the fluids used in drilling.

Wiper

Flexible device mounted on the front of the main frame, installed around the drill pipe as it is being pulled back to help remove mud and debris.

Yield

Change in physical properties of bentonite clay when added to water which allows the particles to remain suspended in solution.

Chapter 1

Safety

The StraightLine 2462 is a powerful tool. Use and maintain it with respect and caution. Your safety and the safety of other persons in the work area are dependent on the proper operation of this machine. The information in this manual is intended to assist you in operating this machine according to established procedures but does not replace any safety rules and laws used in your area.



This safety alert symbol means SAFETY ALERT! This symbol is used both on the machine and in this manual to alert the operator that the message

following the symbol concerns safety. Carefully read the message and make sure you understand the causes of possible injury or death.

The safety alert symbol will be used with these words:

▲ DANGER: Indicates an imminently hazardous situation, which will result in death or serious injury unless avoided.

▲ WARNING: Indicates a potentially hazardous situation, which could result in death or serious injury unless avoided.

▲ CAUTION: Indicates a potential hazardous situation, which may result in minor or moderate injury if not avoided.

Other important information which can help you do a better job, simplify maintenance, or prevent an unsafe situation will be emphasized by the word **IMPORTANT:** followed by an instruction or information.

Operator Qualifications and Training

▲ WARNING

Read this manual carefully before using the Boring System. Consult your StraightLine Dealer or Factory Representative for field instruction advice.



W A R N I N G

BEFORE OPERATING UNIT STUDY OPERATORS MANUAL. READ ALL SAFETY SIGNS ON UNIT, CLEAR AREA OF OTHER PERSONS

LEARN AND PRACTICE SAFE USE OF CONTROLS BEFORE OPERATING

IT IS YOUR RESPONSIBILITY TO UNDERSTAND AND FOLLOW A MANUFACTURER'S INSTRUCTIONS ON MACHINE OPERATION, SERVICE, AND TO OBSERVE PERTINENT LAWS AND REGULATIONS. OPERATOR AND PARTS MANUALS MAY BE OBTAINED FROM YOUR EQUIPMENT DEALER.

Initial training should be done at a non-hazardous site such as an open field, free of utility easements. Training shall include the proper use of safety, protective, and locating equipment.

Operator Safety

▲ WARNING: Always wear O.S.H.A. approved head gear (not provided) when operating at or near drill rack.

Always wear safety glasses (provided) O.S.H.A. approved safety goggles (not provided) to prevent eye injury.

Always wear the three-(3) glove protection system (provided) to guard against electrical shock. Always wear the electrical protection boots (provided) to guard against the possibility of electrical shock caused by the drill pipe contacting an underground utility.



W A R N I N G

1. ALL CREW MEMBERS ARE TO WEAR PROTECTIVE CLOTHING SUCH AS CLASS 2 ELECTRICAL GLOVES AND BOOTS, AND SAFETY GLASSES WHEN BORING OR DRIVING STAKES.
2. BEFORE SETTING UP BORING MACHINE CALL "ONE-CALL" HOTLINE AND HAVE UTILITIES MARKED.
3. EXPOSE UTILITIES BY HAND DIGGING DOWN TO THEM BEFORE CROSSING THEM WITH BORING TOOL.

Machine Safety

▲ DANGER: Turning shaft can crush arms or legs. DO NOT TOUCH DRILL PIPE WHILE ROTATING. Do not wear jewelry, rings, watches or loose clothing when operating drill rack as these items may catch resulting in possible serious injury or death.



▲ WARNING: Moving parts can cut off hands, feet, or fingers. DO NOT TOUCH MOVING PARTS.

▲ WARNING: Pinch points can crush hands or fingers. KEEP YOUR HANDS AWAY FROM MOVING MACHINERY AND PINCH POINTS.

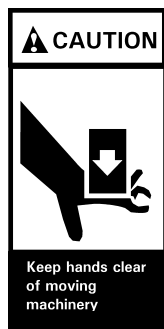

IMPORTANT: Clear all persons and tools from around the drill pipe before starting power supply and then keep bystanders at least 10 ft (3 m) away from turning drill shaft. Do not stand over trench or drill pipe while boring.

IMPORTANT: During pullback operations, material being installed may rotate if swivel malfunctions. Keep all persons away from material being installed.

▲ DANGER POISON! Hydraulic oil under pressure can penetrate the skin and burn or cause blood poisoning. Use a piece of cardboard to check for leaks, NOT YOUR HAND! Before disconnecting any lines, relieve system pressure. Before pressuring up system, be sure all connections are tight and lines, pipes and hoses are NOT damaged. Oil escaping from a very small hole can be almost invisible.

Wear protective clothing and eye protection. If you are injured by pressurized hydraulic fluid, get IMMEDIATE MEDICAL ATTENTION FROM A DOCTOR FAMILIAR WITH THIS TYPE OF INJURY.

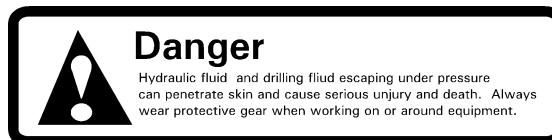

Always make sure that any guards or safety plates are intact and installed properly to insure safe operation.

▲ WARNING: DO NOT ALTER CONTROLS! Do not tie down controls. If releasing a control lever does not cause the motion being controlled to stop, shut down power source and get the unit repaired immediately.

▲ WARNING: Crushing weight. The boring machinery, tools and equipment are heavy and if moved or operated in an unsafe manner can tip over or fall, killing or crushing you.

IMPORTANT: Maintain control of Drill Rack at all times during transport. Have enough manpower or arrange mechanical means (such as a winch) available to prevent rollover and injury. Be particularly aware of tipover hazards when operating on slopes, curbs, uneven or soft ground. In addition be careful when loading and unloading drill from truck or trailer. If the truck or trailer is wet or damp it will be slippery and can cause an accident.

▲ WARNING: Anchor drill rack properly before rotating drill pipe. Failure to properly stake down drill rack can result in drill rack tipover, which can crush and kill the operator.

▲ WARNING: Fire or explosion possible. Fuel and fumes can catch fire or explode and cause serious burns or death.

▲ WARNING: Electrical shock possible. Do not operate the equipment when lightning is possible. Serious injury or death may result.

▲ CAUTION: Slips and falls possible. Do not step in any spilled material (drilling fluid, hydraulic oil, etc.). Falling on slippery surfaces may cause serious personal injury.

▲ CAUTION: Read and understand the Safety and Operation Manual for the Stake Driver. You must use proper safety equipment when operating the Driver. The Stake Driver vibration

is rated at 20m/sec² with a noise rating level of 106 dB (A).

IMPORTANT: Adequate lighting must be provided when operation of this unit occurs beyond daylight hours.

Jobsite Safety

Place jobsite pedestrian and traffic warning barriers in accordance with Federal, State, and Local Regulations. If jobsite workers are exposed to traffic hazards, wear high-visibility safety vests and other protective clothing required by Federal, State and Local regulations.

▲ WARNING: Call your one-call Hotline! Know and comply with regulations covering One-Call service or utility notification before beginning any boring operation including drill rack stake-down. Notify any utilities not represented by the "One-Call Hotline" in your area.

▲ DANGER: Always use the equal potential mats provided with your unit when setting up a jobsite, in preparation of a boring operation. Grid mats are subject to wear. Inspect them each time they are used and replace them as required.

▲ DANGER: Overhead lines. Contacting overhead lines while handling drill pipe may cause death. Know the location of overhead lines and use extreme caution if any are near!

▲ DANGER: Buried underground hazards:

- Electrical power
- Cables, fluid, and gas carrying pipes
- Fiber optic cables

Electrical hits can cause electrocution, pipe hits can cause fire, explosion, asphyxiation or toxic gas or liquid release, and fiber optic cables carry laser-light signals which can cause eye damage.

Jobsite Inspection and Briefing

Take the time to thoroughly check the entire work site yourself for indications of underground hazards. Be alert for "warning signs" such as:

- Notices of buried utilities
- Absence of overhead lines near facilities that logically use utilities

- Gas meters
- Water meters
- Junction boxes
- Manhole covers
- Evidence of previous excavation such as "settled" spots

Use utility locating devices throughout your bore area. Remember they are not perfect, even with an experienced operator. Before crossing an underground utility, carefully hand dig to expose it.

Hold a briefing for all authorized worksite personnel prior to beginning operations. The briefing should include:

- Who is in charge
- Location and type of buried obstructions, services
- Job site security, warning signs, barriers, identify authorized personnel
- Safety considerations associated with operation of the drilling unit, personal protective equipment, clothing, emergency procedures, and emergency telephone numbers

Operating Safety

Use 2-way radio contact between the drill rack operator and the locator to coordinate the boring operation. Have pre-arranged backup hand signals in case the radios fail or cannot be used.

▲ WARNING: Do not trust locating instruments when crossing or boring close to hazardous services. Always expose hazardous utilities by careful hand-digging.

Do not trust locating done previously.

Do not hesitate to contact utilities to shut down services for the duration of the job if there is doubt to location of underground hazards.

Be alert to any change from normal during a boring job.

▶ **LOOK** for leaks, loose connectors, loosening anchors, changes to drilling fluids, problems with tools or drill pipe, or other equipment.

▶ **LISTEN** for unexpected engine lugging, bearing noises, high pressure squeals and any unexpected or unusual rattles, knocks, screeches, or any change to the normal operating noises.

▶ **SMELL** for unusual odors such as hot oil, burning insulation, natural gas, etc.

▶ **FEEL** for changes in the resistance to thrust or rotation during boring or any changes to how the equipment is operating.

▶ **STOP** and correct anything you see, hear, smell, or feel that is potentially unsafe.

Emergency Procedures for Hits

▲ DANGER: Electrocutation Possible. Unprotected bystanders could be electrocuted if in contact with any part of the boring equipment, including the mudskid, if a “hot” line is hit.

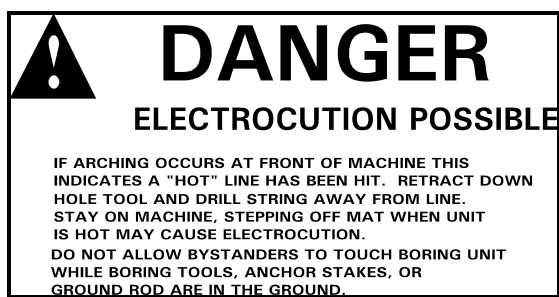

Do not let anyone touch the unit while boring. All persons who come in contact with the boring equipment should always wear protective clothing, such as Class 2 electrical gloves and boots while boring.

BE ALERT! Hitting a “hot” line may be indicated by arcing at the front of the drill rack; a warning on a strike alert device, nearby power outage; smoke, explosion, arcing, etc. on or around nearby electrical transformers and equipment; or nothing at all. Most electrical strikes are not immediately noticeable but are still potentially lethal.

Electrical Hits

If an electrical hit occurs, do not panic.

If you are on the machine, stay on the machine.

If you are standing on the ground, stay where you are and don't touch any equipment.

Stepping off a well-grounded equal potential mat may cause electrocution. If you are off the equipment, remain still and stay off the equipment.

Warn everybody in the area that an electrical strike has occurred and to stay away from the mudskid, drill rack, or any other equipment in the area.

If the operator is on the mat or otherwise in contact with the drill rack, he should retract the downhole tool and drill pipe away from the line. Pull back the carriage to the top of the rack to attempt to disengage from the electrical contact.

▲ WARNING: Do not try to disconnect a drill pipe or joint until electrical power is shut down. Do not rely on electrical circuit breakers as power can be rerouted and circuit breakers can be reset.

Contact the utility company immediately so they can shut off power and arrange repairs.

Gas or Liquid Line Hits

▲ DANGER: Explosion Possible. If a gas or volatile liquid line hit occurs, immediately shut down any power sources such as generators, hydraulic power packs, or vehicles and leave the area. If the power sources cannot readily be shut down, leave the area immediately!

Contact the utility company immediately and warn people in the area. Do not return to the area until given permission by the utility company.

Fiber Optic Cable Hits

▲ CAUTION: Do not look into the severed ends of the cable! Laser light will cause permanent eye damage or blindness. If you do not know what kind of cable you have cut, do not look into the ends in case it is a fiber optic cable.

Safety Summary

Be Aware

Safety is important. Safety precautions and safe operation habits must be the principal consideration before you begin work and continue throughout the job. You should be aware of all hazards overhead, on the surface, and underground before unloading the drill rack from the trailer.

Be Prepared

Take the necessary precautions to protect personnel and bystanders in case of an inadvertent utility hit before anything is driven into the ground. This includes wearing of personal protective equipment, proper jobsite security, and proper training of all jobsite workers.

The most important safety consideration is a well trained crew. Using the proper equipment, the proper tools, in the proper manner on a well planned and well prepared boring job is the best safety policy.

Chapter 2

Equipment Information

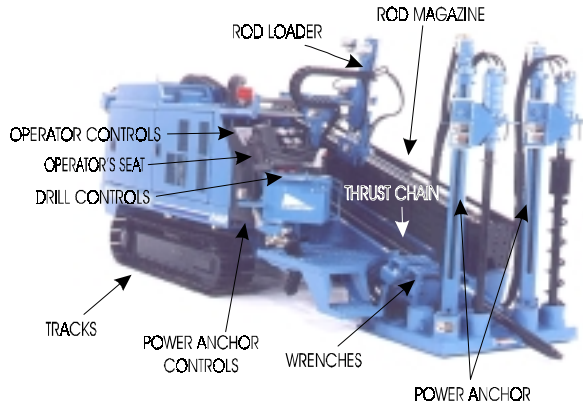

The Engine control panel located to the left of the operator's seat contains the controls and warning indicators for the John Deere power unit. See the engine instruction book for complete safety and operation details of the engine.

1. **Ignition Switch:** This switch has four positions to control the operation of the engine.



Off - In this position the unit is off, the fuel control solenoid is in the "Kill" position, the electrical system is disconnected and the key may be removed.

On - Rotate the key one position clockwise. The on position connects electrical system, the

indicator lamp for the hydraulic oil filter will light up.

Heat - Rotate the key counter clockwise and this connects the cold start preheat (glow plug) circuit. When the temperature is below 40° pre-heat until the indicator light goes out.

Start - Rotate the key two positions past off and this engages the starter. Do not crank the engine for longer than 20 seconds at a time.

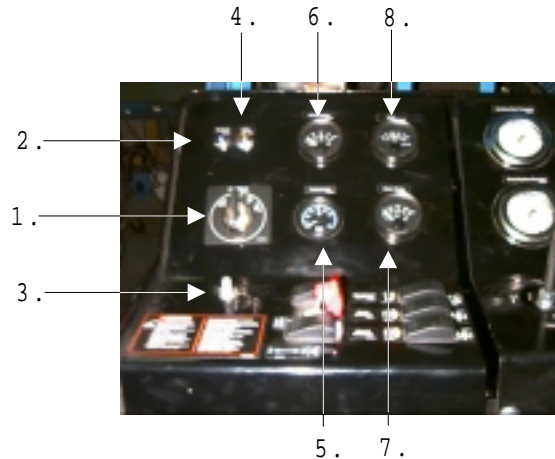

2. **Preheat Indicator:** Shows that the preheat circuit is functioning properly.

3. **Safety Over Ride Switch:** Press and hold during starting to over ride safety shutdown.

4. **Hydraulic Filter Indicator:** Lights when hydraulic charge filters need to be replaced.

5. **Tachometer:** Displays engine RPM.

6. **Oil Pressure Gauge:** Displays engine oil pressure.

7. **Temperature Gauge:** Displays engine coolant temperature.

8. **Volt Meter:** Displays battery voltage.

Operator Control Panel

1. **Makeup Wrench Switch:** This switch controls the makeup (front) wrench. It locks in the clamp position for easy operation of the breakout function.

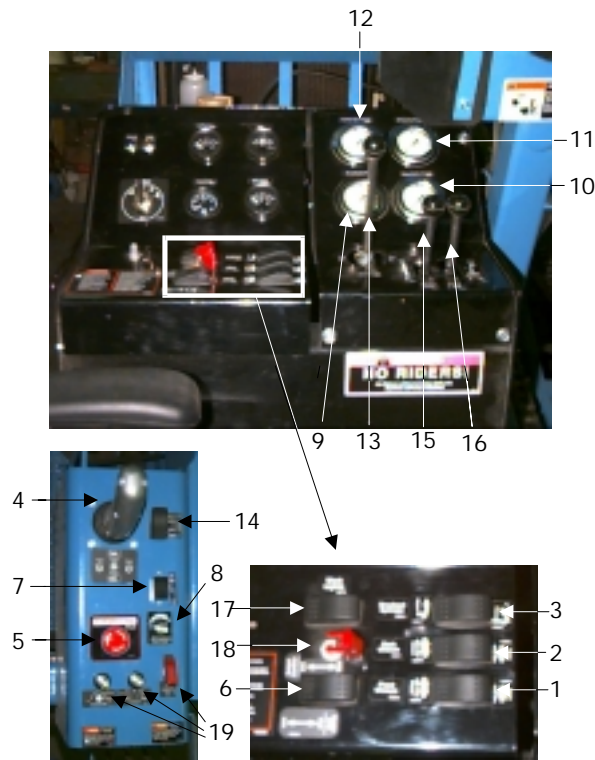

2. **Breakout Wrench Switch:** (rear wrench) Push and hold to clamp the breakout wrench onto the drill pipe.

3. **Breakout Cylinder Switch:** Push and hold to extend the breakout cylinder.

4. **Drill Joystick:** Pull back to move carriage to back (pullback) and push forward to move carriage to front (thrust). Move to the right to rotate the carriage clockwise (forward rotation) and move the joystick to the left to turn the carriage shaft counter clockwise (reverse rotation).

5. **Emergency Shut Down Switch:** Twist and pull out to run. Push in to stop.

6. **Throttle Switch:** Switch rocks one direction for low idle and the other for high idle.

7. **Drilling Fluid Switch:** The drill fluid switch has three settings, Off, On, and Quickfill. The on position is used during thrust and pullback. The Quickfill is primarily used to quickly fill a pipe that is being added to the drillstring.

8. **Drill Fluid Pressure Dial:** Rotate the dial clockwise with the drill fluid switch in the on position to raise drill fluid pressure.

9. **Thrust Gauge:** Indicates hydraulic pressure in the circuit, which is pressurized when in Thrust mode. Indicated pressure should never exceed 5,000 PSI (345 Bar).

10. **Rotation Gauge:** Indicates hydraulic pressure in the circuit, which is pressurized when in the Rotation mode. Indicated pressure should never exceed 5000 PSI (345 Bar).

11. **Drilling Fluid Gauge:** Indicates pressure of the drilling fluid in the drill string and drilling fluid umbilical hose. Indicated pressure should never exceed 1500 PSI (103Bar).

12. **Auxiliary Pressure Gauge:** Indicates hydraulic pressure in the auxiliary circuit. Indicated pressure should never exceed 3000 PSI (207Bar).

13. **Pipe Loader Control Handle:** Move toward drill rack to extend pipe loader, move away from drill rack to retract. Pull toward operator to move loader down, push away from operator to raise.

14. **Pipe Loader Clamp Switch:** Rock forward to close clamp, rock back to open clamp.

15. **Leveling foot control handle:** Push away from operator to lower rear foot and raise the unit, pull toward operator to raise the rear foot and lower the unit.

16. **Auxiliary Hydraulic Circuit Lever:** Pull to turn on power, push to turn off power to the auxiliary hydraulic circuit. Do not operate without something plugged into the auxiliary connections!

17. **Work Lights Switch:** Always use work lights when working in low light conditions.

18. **Drill/Tram Switch:** This switch must be in the drill position for the thrust and rotation operations to function. To tram the machine this switch must be in the tram position.

19. **Autodrill Controls:** See Pullback Operations for instructions on how to use these controls.

Strike Alert

The strike alert is designed with special electronic filters to sense 60 hertz AC electrical power. It uses a red light and siren to alert the operator of current flowing through the grounding cable. The strike alert consists of a control panel mounted on the back of the drill control arm rest, a combination strobe light and 100DB alarm, grounding cables, a six foot long ground rod, and an equal potential mat. The Strike Alert operates with 12VDC electrical power provided by the drilling unit.



Verify that the panel switch is in the “armed” position and the green light is illuminated before driving anchor stakes or drilling. If an electrical utility hit is experienced, the red light and siren will activate and must be reset by switching the front panel switch to the “off” position then back to the “armed” position.

The current sensitivity selector has three positions.

- The .02A position is the most sensitive selection. This position begins sensing at .017A (17mA)
- The .2A position represents a reduction in current sensitivity which begins sensing at .17A (170mA)
- The .50 position is the least sensitive position and begins sensing a .47A (470mA)

IMPORTANT: The panel switch must be returned to the “OFF” position prior to switching between the sensitivity levels to avoid possible false triggering.

Rear Control

1. **Joystick:** Move the joystick forward to drive forward and back to drive in reverse. Move the joystick to the right to move right and left to move left.

CAUTION The joystick controls are very sensitive. Take it slow when you are learning the feel of the motions of the machine. The drawing on the right shows the approximate

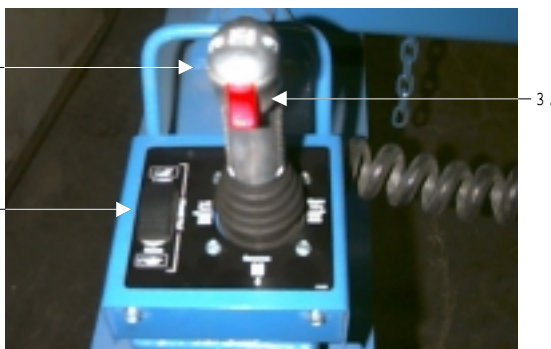
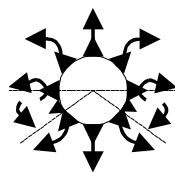

direction the unit will move with each direction of the joystick. Note the area between the dotted lines. At a point, when tramping in reverse, if this line is crossed, the controls will cause the unit to veer *sharply* in the opposite direction.

2. **Tilt Switch:** Push switch toward lower to lower the angle of the drill frame. Push switch toward raise to raise the angle of the drill frame.

3. **Tram Dead Man Switch:** This switch must be held to activate tramping functions.

Fluid Level/Condition Indicators

Hydraulic Fluid: Hydraulic oil level is shown by a sight glass on the side of the hydraulic oil reservoir located at the rear of the unit. The proper level is the mid point between high and low when the oil is cold.

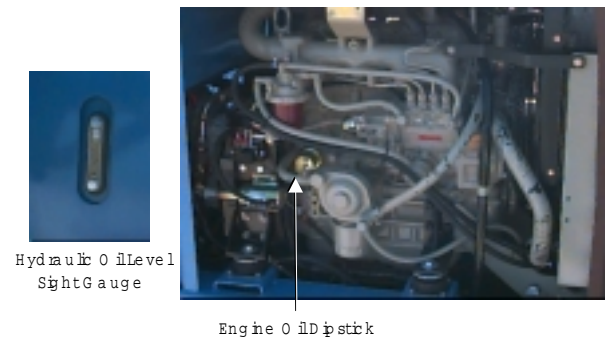

Engine Oil: Engine oil level is shown by a dipstick located on the side of the engine behind the engine enclosure door. Check daily.

Engine Fuel: Diesel fuel tank level is shown by a gauge located in fuel tank behind the operator station.

Hydraulic Oil Filter Condition: The hydraulic return filter on the oil reservoir is equipped with a filter condition gauge. If this gauge reads in the red when the engine is running at high speed and the oil temperature is above 70°F (21°C), the filter should be changed.

Rotation gauge indicator: After machine serial Number 2462037 the rotation gearbox is flushed continuously with oil from the hydraulic reservoir.

The sight gauge is located on top of the rotation gearbox and should be checked daily. If gauge reads in the red and the oil temperature is 70 F the filter should be changed. The filter is located underneath the rack.

Umbilical Connections

1. **Auxiliary Circuit:** The auxiliary circuit, located at the rear of the machine, provides hydraulic power for after market accessories.

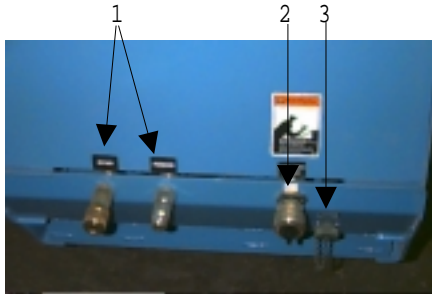

2. **Drilling Fluid:** The drilling fluid supply hose is connected to the drill rack with a valve-less quick coupler. It is not equipped with a check valve to simplify drainage and cleaning.

3. **Mud Skid Electrical Control:** The electrical control umbilical is connected with a multi-pin plug at the rear of the unit. This electrical cable controls the on/off and the amount of volume of the drilling fluid circuit. The cable is normally stored on the mud skid.

Grounding Cable: The ground cable makes a connection from the ground rod to a lug on the mud skid. The cable is normally stored on the mud skid.

Engine Compartment

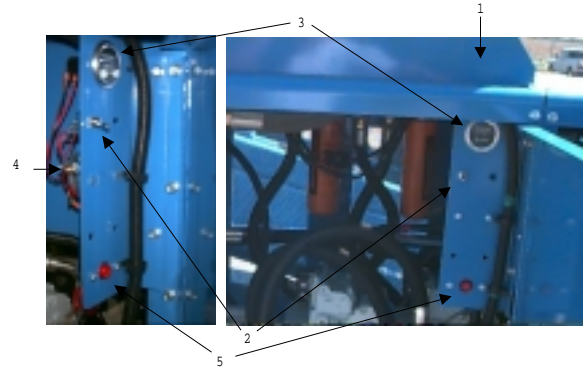

1. **Hydraulic Oil Cooler:** This unit is equipped with two electrically powered and controlled oil cooler fans. This is an automatic system, the thermostat is set to turn on the cooling system when the oil temperature reaches 120°F (49°C).

2. **Override Switch:** This switch will override the automatic thermostat on the oil cooler. Toggle this switch up to manually turn on the cooler fan(s). Toggle this switch down for automatic operation.

3. **Hour meter:** This indicates the run time on the unit.

4. **Relay:** This relay controls the power to the cooler fan motors.

5. **40 Amp Circuit Breaker:** This Breaker protects the power circuit to the cooling fan motor(s).

Engine Coolant

The coolant should be a 50/50 mixture of water and anti-freeze. There is an access panel in the top of the engine enclosure to reach the radiator fill neck. Even in summer, the freeze protection should always be at least -35°.

Battery

The unit is equipped with a 12v 950 cold cranking amp battery.

Chapter 3

Planning the Bore

Information

Successful bores begin well before the first pipe goes in the ground. Find and review any existing information already available about the job and jobsite. The basics include length, depth, and obstacles for the planned bore.

♦ **Job Plan:** Check for information on existing or planned structures, and their elevations. Check for any proposed work that may be taking place. If possible, review their plans or documentation of the jobsite. Contact local authorities about safety procedures and regulations.

♦ **Pullback Material:** Verify the material you will be pulling back, its bend radius, weight and stiffness.

♦ **One-Call Services:** Call area One-Call or similar services and have existing lines located and marked. Call any utilities in your area that do not subscribe to One-Call.

♦ **Traffic Control:** Contact local authorities about safety procedures and regulations, when working near a road or other traffic area.

♦ **Emergency Services:** Find the telephone numbers for local emergency and medical facilities at hand. Develop an emergency action plan including telephone locations and backup.

Site Inspection

Inspect jobsite before transporting equipment. Check for the following:

♦ Identify Hazards

▲ **Warning:** Jobsite hazards could cause death or serious injury. Use only the correct equipment and safe work methods. Always use and maintain proper safety equipment.

- ♦ Signs of Utilities (See “Safety” section)
- ♦ Observe and comply with any jobsite notices
- ♦ Survey the job site for changes in elevation
- ♦ Identify obstacles such as buildings, roads, streams, railroad tracks, and the like.
- ♦ Access

- ♦ Traffic
- ♦ Soil type and condition
- ♦ Water supply
- ♦ Sources of locator interference (power lines, railroad tracks, etc.)

Plan the Bore Path

The bore path must be planned before boring begins, from entry to exit. The bore path can be marked on the ground with spray paint or flags, or written on paper for operator reference.

The lay out of the bore path must consider depth of the bore, recommended steering limits, entry grade, and set-back distance. The entry and exit points can be marked once the desired depth and set back distances are determined.

Depth: Generally, the conditions found on the jobsite will determine the depth of the bore. To reduce depth, reduce entry angle. To increase depth, increase entry angle and set-back. Also consider the selection of the transmitter.

Steering limits: The 2462 has a minimum bend radius of 130 feet. This translates to no more than a 7% change in grade in one length of drill pipe on a vertical steer, or 130 feet of forward distance (not 130 feet of pipe) to make a 90 degree turn.

Important: “Over-steering” or bending the pipe more sharply than recommended limits will damage and shorten the life of the pipe. This damage is not always visible. Repeated abuse of the steering limits will result in bent or broken pipe that may make recovery of the drill head, transmitter, backreamer or utility difficult or impossible.

Entry Angle: This is the angle of the boring unit as compared to the angle of ground. A shallow entry angle allows you to reach horizontal sooner and with less bending. Increasing entry angle makes bore path longer and deeper.

Set-back Distance: This is the distance from entry to where the pipe will run horizontal. If set-back distance is too short, the steering limits will be exceeded and the drill pipe can be damaged.

Traffic: Vehicle and pedestrian traffic must be a safe distance from boring equipment. Allow at least 10' (3m) buffer zone around equipment.

Slope: Fluid system should be parked on a level site. Consider how slope will affect boring unit set-up, bending pipe and fluid flow out of hole.

Evaluate The Soil Conditions

Soil conditions include (but are not limited to) compaction, moisture content, porosity, stickiness, presence of rocks, and underground water formations. These conditions can be determined by several methods. These methods escalate in complexity ranging from simply

inquiring about underground experience in the area, to inspection of local open-cut excavations, to hand digging, and ultimately to core sample drilling with geologic evaluation.

Select the Tooling

The selection of tooling depends on the soil conditions at the job site and the material to be installed.

Select The Drilling Fluid

The selection and mixture of drilling fluid also depends on the soil at the job site and the material to be installed.

Checklist

Use the checklist on the following page as a guide to plan your bore.

Planning the Bore Checklist

Brief the Crew

- Survey the job site, locate and mark all underground utilities
- Brief the crew on all known hazards
- Expose all proposed crossings
- Plan the pilot bore, confirm that a bore log is at hand, and mark the proposed bore path
- Assign adequate manpower where needed
- Confirm emergency procedures, and access to emergency phones and numbers
- Location of all safety barriers and the appropriate precautions to secure the jobsite and equipment.
- Confirm that the crew has and wears appropriate safety gear.

Supplies:

- Receiver/locator with charged batteries
- Transmitter and spare batteries
- Two way radios and spare batteries
- Wrenches and shear bolts
- Anchoring equipment and accessories
- Allen bolts and wrenches
- Bits, filters, jets
- Adapters, pipe, transmitter head
- Marking flags, paint
- Water and additional hoses

- Bentonite/polymer
- Spare Fuses
- Keys
- Tooling, Backreamers, swivels, pulling devices
- Wash wand and hose
- Duct tape
- Spray lubricant
- Thread lubricant and brush
- Notepad and pencil

Equipment

- Fuel
- Hydraulic fluid
- Engine oil
- Battery
- Lube points
- Thrust chain
- Filters (air, oil, hydraulic)
- Fluid pump
- Couplers
- Tracks
- Mud mixer
- Hoses and valves
- Fluid solenoid
- Water tanks
- Wrenches
- Equal potential mats and cables in good condition

Chapter 4

Setup at the Job Site

Upon arrival at the job site, park the trailer on a level area that is close enough to where the drill rack will be anchored to allow the umbilicals to be easily connected. Use wheel chocks and the tongue jack to prevent the trailer from unexpectedly moving before starting to unload the drill rack. When the trailer has been securely parked, then the safety barriers, traffic cones, hazard lights, etc. around the trailer should be erected and activated to prevent non-authorized personnel from coming in contact with the equipment.

Unload The Drill Rack

⚠ WARNING: Crushing Weight, if moved or operated in an unsafe manner, this equipment can crush operators or bystanders.

Refer to the equipment information (Chapter 2) to identify and operate the controls of the unit. Carefully tram the drill rack off the trailer and to the bore entry location. Maintain control of the drill rack at all times. If the trailer is damp or wet the drill will have the possibility of sliding out of control.

Position The Drill Rack

If the drill rack position is on uneven terrain, such as an embankment, the setback between the drill rack and the entry point should be adjusted to compensate for the change in the geometry. If set up on an incline is unavoidable, do not exceed a maximum incline of 30° to maintain proper engine lubrication. If necessary, start the engine and position the drill rack for the desired drill pipe entry angle with the level foot and the tilt control. When finished, always shut the engine off.

Setup the Strike Alert

⚠ WARNING: The Strike Alert system indicates only that the drill has come into contact with electrical power, you must wear the proper protective clothing for recommended protection.

When the drill rack is in position, unroll the equal potential mat and position it with the ground cable socket towards the front and close to the center of the anchor site. Position the mat on the side of the unit that will provide the most protection for the crew while drill pipe is in the ground. Normal positioning will be on the right hand side. If there is ever a need for manual loading of the drill pipe, place it on the left side.

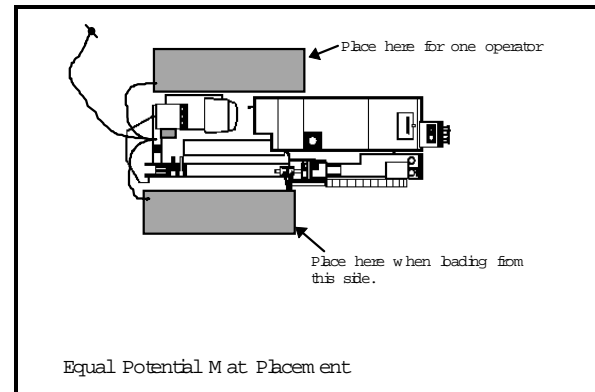

⚠ DANGER: Electric Shock. Put on electrical insulating boots and gloves, then anchor the mat in position using the mat stakes provided, making sure that the mat and stakes are flush with the ground to prevent a tripping hazard.

Drive the ground stake into the ground until no more than 1 foot is left exposed. If the ground is extremely dry, pour water down and around the ground rod to help with a proper ground. The earth ground should be tested with a device such as a Megger to determine the resistance to ground.

Make the cable connections to the equal potential mat, Strike Alert, the drill rack, and the

ground rod. Now connect the ground umbilical between the mud skid and the drill rack. Arrange the path of the umbilical so as to avoid having to walk on or over the umbilical which can cause premature wear and damage.

Check the Strike Alert system before driving the anchors or using the power anchor system. Place the front panel switch in the “test” position and verify the operation of the red light and siren. If the red light and siren do not operate in the “test” position, verify that the key switch is turned on. Also check that the battery is charged and properly connected.

After the unit has operated with the switch in the “test” position, put the switch in the “armed” position and verify the green light is illuminated.

Anchor The Drill Rack

▲ WARNING: Be sure to properly anchor the drill rack, both in the front and in the rear of the machine before rotating drill pipe. If the rear of the machine needs to be anchored additional anchor stakes are required along with an anchor driver and anchor puller. Failure to properly anchor the drill rack to the ground can result in damaged tooling and excessive drill pipe wear and even drill rack tip over, which can crush you when the drill string is rotated. If the operator has not already done so all proper safety equipment should be worn while operating any anchor system.

IMPORTANT: Failure to securely anchor drill rack allows premature drill pipe and drill pipe guide wear. Premature drill pipe wear is usually discovered by drill pipe breakage under load, underground. Proper use of anchors could prevent future use of shovels (digging up drill head) or checkbook (buying new drill head, sonde, etc.) by keeping drill pipe centered in drill pipe guide. **STAKE IT FIRMLY DOWN TO THE GROUND!**

Power Anchor Operation

The power anchors are operated by the controls located on the operator station. The handles control the thrust and rotation for each power anchor. The power anchor is equipped with augers that have flighting for soil or smooth stakes equipped with carbide bits for anchoring in asphalt, concrete or rock. Attach the appropriate stake to the power anchor motor using the pins and couplers provided with the machine on the side desired to anchor.

▲ DANGER: To protect the operator and personnel around the anchor system the pins and couplers that attach the anchors to the thrust motors must be installed correctly. The power anchor should never be operated while someone is near to the rotating parts of the system

With maximum thrust slowly rotate the anchor into the socket provided in the anchor plate. The operator should not use the power anchor to dig a hole but, use the power anchor to insert the stake into the ground. If the stake is inserted correctly the surface of the ground should remain relatively undisturbed. The operator can place three stakes on either side of the anchor plate with the power anchor. After one stake has been placed disconnect the pin between the thrust motor and the top of the auger, raise the thrust motor to the top of the mast then lift the latch at the base to allow the power anchor to swivel to the next position. Confirm the power anchor is positioned correctly by engaging the latch into the notch provided. Repeat the procedure above for as many stakes as the operator would like to put in.

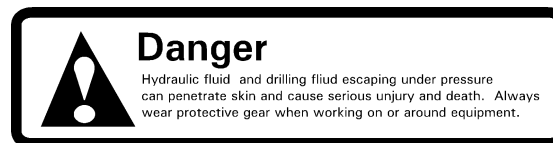

If you have not already done so, put on the electrical insulating boots and gloves. Start the engine and activate the driver circuit by moving the anchor/puller control valve lever at the front control panel. Place the hammer end of the driver on a stake with the stake aligned through a hole in the anchor plate, squeeze the trigger to start the driver, (adequate down pressure is very important). Continue driving until the stake collar is against the anchor plate. Repeat for each stake to be driven.

IMPORTANT: “Do not” operate the driver without holding it against a work surface, this puts an excessive strain on the driver’s foot and other internal components.

Prepare the Drilling Fluid

StraightLine’s mud systems mix as well as pump high pressure drilling fluid to the drilling unit. They are equipped with a venturi system to introduce bentonite to the mixture.

IMPORTANT: Read the engine Operators Manual for complete instructions on starting and running the engine(s).

Mixing Bentonite

Start the engine and, after proper warm up, set to high throttle. With water in the main tank, set the Selector Valve handle to mix and the drilling fluid switch off. Pour bentonite into the hopper and slowly open the ball valve. Follow all the supplier's instructions for best results.

IMPORTANT: Do not allow too much material at once or the venturi will clog.

Mixing Polymers

With water in the main tank, set the Selector Valve handle to mix and the drilling fluid switch off. Start the engine and set to high throttle. Add the correct amount of polymers directly into the main tank, do not use the venturi system.

Connect the Mud Skid Umbilicals.

The operator at the drill rack should confirm that the mud skid umbilical connections are correct by

momentary operation of the drilling fluid switch. Don't start to bore until the following items are also completed.

See the mud system operator's manual for complete and detailed instructions.

SET UP CHECK LIST

- | | |
|---|--|
| <input type="checkbox"/> Brief the crew on all known hazards | <input type="checkbox"/> Service the drill rack and mud skid including the fuel and oil levels |
| <input type="checkbox"/> Survey the job site, locate and mark all underground utilities | <input type="checkbox"/> Service any trailer mounted equipment |
| <input type="checkbox"/> Expose all proposed crossings | <input type="checkbox"/> Mix the drilling fluid thoroughly using suitable water and test the drilling fluid for viscosity, sand content, filter cake, or other factors as required |
| <input type="checkbox"/> The proposed bore path is marked, and bore log at hand. | <input type="checkbox"/> Set the drilling fluid speed control valve lever on the mud skid and measure the flow rate |
| <input type="checkbox"/> Confirm that the crew is trained in emergency procedures, and has access to emergency phone numbers | <input type="checkbox"/> Confirm that the whole crew is wearing all appropriate safety gear |
| <input type="checkbox"/> Secure and anchor the drill rack | <input type="checkbox"/> Install fresh batteries in the transmitter, and confirm that a fully charged battery pack is in the locator receiver |
| <input type="checkbox"/> Connect the ground mats to a tested ground stake | <input type="checkbox"/> Calibrate the locator receiver per the locator's operator's manual |
| <input type="checkbox"/> Erect all safety barriers and take the appropriate precautions to secure the job site and equipment. | <input type="checkbox"/> Test the radio communications between the locator and the operator |
| <input type="checkbox"/> Check the tooling, is there an adequate amount of drill pipe, thread lube, and supplies to mix drilling fluid. | |

Starting the Pilot Bore

Thread Lube

Apply thread lubricant to the tool joint using the brush provided. The lubricant should fully coat all threads on both halves of the tool joint and should also coat the shoulder of the makeup pipe joint.

Important: For optimum operation and to prolong the life of the drill pipe, always use thread lube on every pipe change beginning with the very first section installed.

If the drill pipe is new or has not been used in three or more days, apply a generous coating to the shoulder and threads of both the male and female ends. Otherwise, apply a generous coating to the shoulder and male threads before the tool joint is screwed together.

Tighten Joints At The Saver Sub.

Open both wrenches. Using the pipe loader, move the first piece of pipe onto the pipe catcher with the front (male) near the wrenches and the rear (female) end positioned directly in front of the saver-sub.

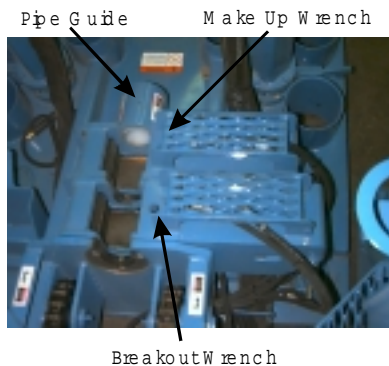

Slowly thrust forward until the front (male) end of the pipe is in the jaws of the makeup wrench. Tighten the section of drill pipe onto the saver sub by locking the makeup wrench. Using forward rotation, turn the pipe until it is tightened to full drill rotation torque.

Set the makeup wrench back to neutral. The drill pipe should be advanced (thrust forward) through the makeup wrench and the drill pipe

guide to expose the male threads in front of the drill rack so that the drill head assembly may be attached.

Assemble the Drill Head

Assemble the drill head with the appropriate filter for the drilling fluid selected, Sonde, bit, and fluid jets. Use thread compound on all bolts.

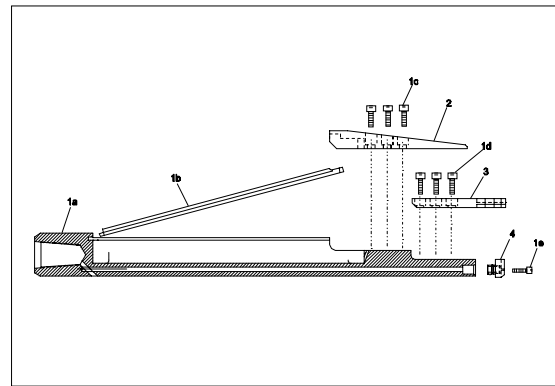

Apply thread lube to the male end of the drill pipe. Attach the drill head assembly by screwing it on the drill pipe and tighten with hand wrenches.

⚠ DANGER: Turning shaft can crush arms or legs. Do not touch drill pipe while rotating. Do not wear jewelry, rings, watches, or loose clothing when operating drill rack as these items may catch resulting in serious injury or death.



Check the Jets

Toggle the drilling fluid pump control switch to the quick fill position and run fluid through the umbilical, swivel, drill pipe, filter, and jets.

Observe the pattern of fluid spray from the jets to make sure that the system is operating properly.

Important: If there is any foreign material clogging the fluid jets, remove and clean the filter as well as the jets before re-testing. Checking the condition of the filter can be done more easily at this point than at any other time during the job. If any restrictions or other problems occur, solve them before continuing the bore.

When you're ready to proceed and fluid comes out of the jets release the switch. It should relax to the on position. Set the desired drilling fluid pressure with the drill fluid dial. Apply forward rotation and hold.

Important: Whenever you are advancing the drill head, you must have fluid (under pressure) flowing through the drill head to insure the jets do not become clogged.

Important: The pressure will register on the drilling solution gauge even if the drill head jets have become clogged. There is an easy way to check for clogged jets. Turn the drilling fluid pump control switch on and watch the drilling fluid pressure gauge until it registers pressure. Turn the switch off and monitor the pressure reading on the gauge. If the pressure falls off quickly, the jets are not clogged. If the pressure takes some time to drop off, the jets are clogged.

Dig A Pilot Hole

Dig a starting hole to give the drill a flat surface into which the bore may begin with out deflection.

Being perfectly aligned when beginning the bore is absolutely necessary for fast easy drill pipe addition during the boring operation and easy pipe removal during the pullback operation. An off-center entry hole causes unnecessary pressure on the tool joints, reducing the useful life of both the drill pipe and the tool joints. The increased side pressure caused by an off center entry hole increases the horsepower requirements for boring, steering, and pullback which reduces the capacity of the entire drilling system.

Advance (thrust forward) the drill head slowly by feathering the joystick to control movement and rotating (forward) until the drill head is all the way to the front end of the drill rack with the back (female) tool joint of the drill pipe in the makeup wrench.

⚠ DANGER: Do not touch the drill pipe while it is rotating. Do not wear jewelry, rings, watches, or loose clothing when operating drill rack as these items may catch, resulting in serious injury or death.

⚠ WARNING: Do not wire, wedge, tape, or tie down controls in any way. Maintain personal control of the boring equipment at all times.

⚠ DANGER: Electrical Shock. Know the location of all electrical lines and stay at least 10 feet (3m) away from all "hot" electrical lines, including overhead lines. Contacting electrical lines with drill pipe, whether drilling underground or handling pipe above ground, will cause serious injury or death.

Completing the Pilot Bore

Adding Drill Pipe

To begin adding drill pipe, turn the drilling fluid pump off and lock the female tool joint in the make-up wrench.

Apply reverse rotation to break the sub saver joint lose. Continue reverse rotation until the saver sub is completely disengaged from the drill pipe. The 2462 is equipped with a floating carriage system that allows enough idle, linear movement to thread and unthread drill pipe.

Apply thread lube to the saver sub and again, using the pipe loader, move a new section of drill pipe in position between the exposed tool joint in the make-up wrench and the saver sub onto the pipe catcher. Apply ample thread lube to the male end of the drill pipe.

Slowly rotate the saver sub into the new drill pipe providing a loose fit. Remove the pipe loader and advance the carriage until the male tool joint of the new section of pipe threads into the female joint of the exposed pipe. Slowly rotate (forward) to shoulder up the tool joint threads to full rotation torque.

Set the makeup wrench cylinder to the neutral position. Be very careful not to thrust with either of the wrenches locked onto the tool joints. Thrusting in either direction with the wrench jaws locked onto the pipe can cause damage to both the pipe joints and the wrenches.

Important: Take special notice of the sequence in which functions and switches are turned on and off. Following them will reduce the possibility of injury or damage to the equipment. Rock the drilling fluid pump switch to the quick fill position. When the drilling fluid gauge registers pressure, relax the switch to on and rotate (forward) and thrust (forward) to bore, or thrust (forward) only to push or steer as required until the female tool joint reaches the inside of the makeup wrench.

Important: Do not rotate drill string in reverse, any time the drill string or pipe is in the ground.

This can cause the drill pipe to loosen and come apart underground.

Check the fluid usage after the drill head has been advanced approximately 30 feet and adjust as required.

Guiding the Bore

Guiding the drill head through the planned bore path is accomplished by connecting straight runs of rotation with curved runs of steering. This process relies on the use of locating equipment and experienced operators.

Steering or “pushing” involves rotating the drill head to orient the steering shoe, and pushing the drill head without rotating to cause the head to veer in a controlled direction.

In order to bore (rotate) or steer (push) with accuracy, the direction and pitch and roll of the drill head must be known before thrust force is applied. Modern tracking and locating equipment provide that information and give precise position and depth information. Refer to the operator’s manual supplied with the tracking or locating equipment to learn how to most accurately guide the drill head.

Boring

When advancing the drill head without steering, the locator tells the operator to “rotate” and reports the distance to advance.

The operator turns the drilling fluid switch on, and waits until the pressure registers on the drilling fluid pressure gauge. Then engage, rotate (forward) and slowly advance thrust (forward) until a new drill pipe must be added or the distance requested by the locator has been advanced.

Advancing the drill head at the correct speed is critical when boring or steering. Monitor the thrust and rotation hydraulic pressure gauges, pressure readings will correspond to the amount of resistance in the respective functions. Learning to “read” the information these gauges

furnish will help determine how fast you may safely advance the drill string.

At this point, the operator stops thrust first, then allows a few revolutions of rotation to release torque windup in the drill string, and then turns the drilling fluid switch off.

Steering

The first steer is usually performed to change the grade from the point of entry to the first level run. When the drill head is at the point of the bore path where the steering arc levels off and the desired depth is reached, the operator first stops the thrust. The drill head is then rotated a few revolutions to release windup and the drilling fluid switch is turned off.

The locator marks the position of the drill head and reads the orientation of the steering shoe. The drill head orientation and steering directions are given in terms of "clock" position with the clock face viewed from the operator position. The drill head will steer in the direction of its clock position with 12 o'clock being straight up, 3 o'clock being a level right turn, etc. Therefore to change from a downward entry bore path to level bore path, the drill head needs to steer to the 12 o'clock direction.

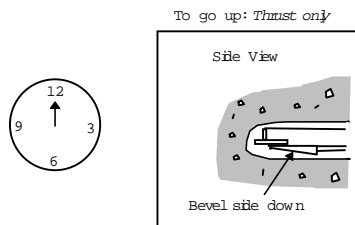

The locator using the locating device will analyze the stopped and the desired clock position of the drill head. He then must determine the desired drill head position and communicate this to the operator. The operator notes the orientation of the exposed drill pipe or saver sub and rotates the appropriate number of "hours" in order to put the steering shoe in the correct position for the steer.

The locator confirms the new orientation of the drill head and tells the operator the distance to push at that clock position.

The operator turns the drilling fluid switch on, insures that there is pressure on the drilling fluid gauge, then engages thrust (forward) feathering the valve to control speed. The operator pushes the drill pipe ahead for the distance requested, then stops the thrust, and turns the drilling fluid switch off.

The locator marks the new position, notes the depth (and pitch if available) and determines the need for any additional steering requirements. If pitch information is not provided on the locator device, a short straight bore with precise depth reading will indicate whether or not the drill head is level.

The locator should mark the progress of the bore on the surface at least every 5-6 feet if possible, more often, if necessary. Keep track of the actual bore path in the bore log by recording the depths at each location point.

Finishing the Pilot Bore

The pilot bore can be guided to a pit but is usually accomplished by steering the drillhead up to the surface at the planned exit point. Make sure that the upward curve of the bore path at the exit does not exceed the bend radius of the drill pipe or the material to be installed. The last steering curve is the first pullback curve, so all installed material will bend around this curve. It is good practice to maintain as straight a bore path as possible.

When the locator can verify that the drill head is on an upward path and is about to emerge, secure the area around the exit point. When the drill has emerged the operator should toggle the drilling fluid pump to OFF and advance the drill string until the drill head and filter sub are clear of the ground. Shut down the power unit and remove the key from the ignition switch before starting the preparation for pullback operations.

Thoroughly clean and flush the drill head. Inspect for damage and wear to the cutting bit and the steering shoe. Open the transmitter housing cover and remove the transmitter. Clean off the transmitter, remove batteries, and return the transmitter and locator receiver to the transport/storage case. Return the drill head to its storage place on the trailer.

Chapter 7

Pullback Operations

Pullback operations involve two individual tasks that are usually done together:

Back-reaming: The process of enlarging the pilot bore.

Pullback: The process of pulling the utility into the tunnel with a swivel.

Drilling fluid management and tooling selection are very important to successful pullbacks. The demand on horsepower can be greatly reduced, and the quality of the tunnel can be greatly improved through proper management and equipment.

Pullback Safety

The pilot bore may have guided the drill string in near proximity to an unmarked hazard that went undetected. Back-reaming enlarges the pilot bore, and may now bring the drill string in contact with that hazard. This contact has all the same consequences of a utility hit on the pilot bore. Observe all of the safety rules for the pull back as the pilot bore.

⚠ DANGER: Electrocutation Possible. If arching occurs at the front of machine, this indicates a “HOT” line has been hit. Anyone could be electrocuted from contact with any part of the boring equipment, including the mud skid.

⚠ DANGER: Turning shaft can crush arms or legs. Do not touch drill pipe while rotating. Do not wear jewelry, rings, watches, or loose clothing when operation drill rack as these items may catch resulting in serious injury or death.



⚠ WARNING Keep all persons away from material being installed during pullback

operations. The material being installed may rotate unexpectedly if swivel malfunctions.

Assemble The Tooling

Apply a liberal amount of thread lube to the threads of all the tooling. Make sure the threads are fully seated and tightened. Check to see that the jets are properly sized and functioning. The swivel should be properly lubricated and in good operating condition.

With all systems shut off, assemble the tooling to the drill pipe and attach the material being installed with the appropriate puller, adapters, swivel, and/or attaching hardware.



Start the Pullback

Position a crew member at the exit hole to communicate the status of the drilling fluid flow to the operator at the drill rack, and also to monitor the utility being installed.



Communication of the fluid situation to the operator will help regulate the speed of the pullback to prevent “outrunning” the drilling fluid or allowing the returns to pack off and “stick” the installed material.

Start the engine of the drill rack and mud skid. Turn the drilling fluid switch on momentarily to check the jets.



Thrust as required to position the next tool joint between the wrenches and disconnect the saver-sub from the drill pipe following the procedure used in adding drill pipe.

Thrust (forward) to position the saver-sub through the breakout wrench and using the procedure used in adding drill pipe, connect the saver-sub to drill pipe.

Thrust (reverse) slowly to retract the drill string until the backreaming tool contacts the earth at the exit hole.

Important: Do Not rotate drill string in reverse (counter-clockwise) while drilling, backreaming, or anytime the drill string is in the ground. This may allow the drill pipe sections to loosen and come apart underground.

Rotate (forward) at full speed, turn the drilling fluid switch on and thrust (reverse) retracting the drill string, feathering the thrust valve as required to maintain a steady pull without overloading the drill rack, tooling, or material being installed. The auto drill feature makes this a fairly simple task. (See Auto Drill)

Monitor the thrust and rotation hydraulic pressure gauges, pressure readings will correspond to the amount of resistance in the respective functions. Learning to “read” the information these gauges furnish will help determine how fast you may safely pullback.

NOTE: Drilling fluid management during pullback is critical to prevent excess drag and related problems. The amount of fluid being pumped around the backreamer and material being pulled back is controlled by the setting of the fluid pump speed control and the speed of the pullback. The proper speed of pullback and the

proper flow rate is another “it depends” calculations. The locator who is at the exit hole (material entry point) should carefully monitor the exit hole for fluid, which should be present but not in excess.

Auto Drill

The autodrill function of the 2462 is used to aid in consistent hole formation and in optimizing the available power of the drill.

⚠ WARNING It is important to remember that the controls for thrust and rotation should be set to neutral before turning the autodrill on for the first time on each bore to prevent unexpected operation when the switch is turned on.

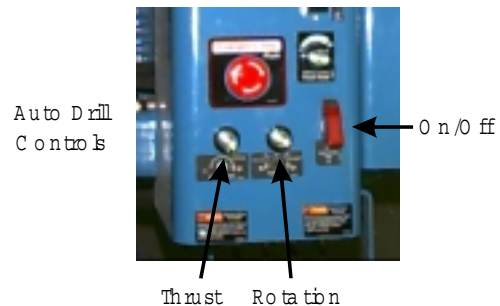

With the thrust and rotation knobs set to neutral, toggle the auto drill switch to on. Now, turn the rotary control knob to the desired speed, then increase the pullback until the desired load on the spindle or the desired pullback rate is achieved. After the desired rates have been set, resetting the controller should not be necessary until ground conditions change. The on/off switch should then be used to engage and disengage the autodrill function. Remembering to monitor the rotational speed and being sure not to pullback faster than the mud pump can fill the hole being cut are the key factors to proper hole formation.

Removing Drill Pipe

Continue until the next drill pipe tool joint is positioned between the breakout wrench and the makeup wrench. Stop thrust, and rotation, turn the drilling fluid switch off.

Important: Some utility material is “elastic” and may pull the drill pipe back towards the tunnel when the saver sub is disconnected. If you experience this:

1. Slow the speed of the pullback to allow the material to stay normalized
2. Increase fluid flow to better lubricate or “float:” the material being pulled
3. Pull the pipe joint a bit past the wrenches, then push it back into the correct position to relieve the tension before breaking the drill pipe joint.
4. Use the make-up wrench to help hold string.

Breakout

With the make-up wrench clamped, clamp the breakout wrench and extend breakout cylinder to break the drill pipe loose from the drill string.

Important: Rotate (reverse) slowly as the tool joint loosens between the sections of drill pipe to prevent “backdrive” of the rotation motor. This action will prolong the life of the rotation drive components. Set the breakout wrench to its neutral position. Slowly rotate (reverse) to release the threads in the tool joint. Stop movement when the threads clear but the tool joint remains in the jaws of the breakout wrench.

Close the breakout wrench, rotate (reverse) to break the joint between the drill pipe and the saver sub. Set the breakout wrench cylinder to its neutral position

Grasp the drill pipe with the pipe loader and continue to rotate (reverse) until the drill pipe is completely disconnected from the saver-sub, then place the drill pipe in the storage rack.

Thrust (forward), and apply thread lube to the saver-sub as it moves into position through the breakout wrench to align with the next tool joint.

Important: Always apply thread lube to the saver-sub on every joint for optimum operation and to prolong the life of the drill pipe.

Retract the makeup wrench, and then slowly rotate (forward) connecting the saver-sub to the drill string. Continue to rotate (forward) and tighten the joint to full system torque.

Set the Makeup Wrench to its neutral position.

Turn the drilling fluid switch on, when pressure registers, rotate (forward) and thrust (reverse) to carefully continue the pullback.

Repeat as necessary until the backreamer is about to emerge from the entry hole.

COMPLETING THE PULLBACK

Retract the carriage to the rear of the drill rack then forward to release the tension on the pulling swivel.

Shut down the drill rack and remove the key from the ignition switch.

Disconnect the now installed material from the swivel by removing the pulling connectors from the material and the swivel clevis.

Remove the swivel from the drill string, clean, and repack with water resistant grease. immediately.

Remove the backreamer and the filter sub from the drill pipe.

Cleaning the dirt and mud off the equipment will make the next setup easier. If clean water is available on site, it is a good idea to wash things off as they are loaded. If not, clean off when possible.

Restart the drill rack and position the front tool joint of the last section of drill pipe in the breakout wrench.

Close the breakout wrench and rotate (reverse) to break the saver-sub loose from the last remaining drill pipe and continue until the joint is almost apart. Set the breakout wrench to its neutral position, grasp the drill pipe with the pipe loader and when it releases, place in the drill pipe storage rack.

Pullback operations are usually best done as a non-stop operation from start to finish. Before starting, complete this checklist to prevent stoppages in your work during pullback.

Pullback Checklist

- Fuel and oil levels
- Drilling fluid and supplies
- Utility supplies and conditions
- Apply a liberal amount of "Taper-Lube" grease to the threads of all the tooling
- Check the pullback swivel and lube with water-proof "Jet-Lube"
- Install the drill pipe wiper over the drill pipe at the front of the drill pipe guide
- Attach the backreamer(s) and pulling swivel to the drill string. Make sure the threads are fully seated and tightened
- Use the appropriate pullers, adapters and attaching hardware to connect the material to the swivel
- Test the radio communication between the observer and the operator.

Chapter 8

Shutdown

Power Anchor

Using the controls at the operator station slowly unscrew the power anchor stakes out of the ground. Do not pull the stakes with the thrust motors. Use rotation and thrust together to gently remove stakes out of the soil. Failure to this procedure will cause premature failure of the lead screws, which will render the power anchor useless.

Remove the Stakes

Inspect the stake puller hose ends for damage or dirt. Clean and repair as needed. The engine must not be running. Connect the stake puller to the quick disconnect couplings provided at the rear of the unit.

⚠ Caution: Secure the hydraulic couplers by rotating the lock ring of the female coupler half to the lock position. Failure to secure the couplers could restrict circuit fluid flow causing erratic performance or unexpectedly disconnect under pressure.

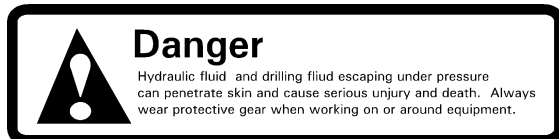

Retract the puller and slide the foot over the top of the stake. Place the horseshoe shaped clip into the annular groove at the top of the stake to lock the puller onto the stake.

Position the puller foot so it will push against the anchor plate. A crew member holds the puller in position, as another actuates the puller by operating the anchor/puller lever on the operator control panel. If the stake gets cocked at an angle, it may be necessary to stop and reposition the puller so that the stake will more easily pull through the anchor plate.

⚠ WARNING: Crushing power, if moved or operated in an unsafe manner this equipment can crush operators or bystanders.

Extensions are provided to fully retract the stake if necessary. When the stake is loosened to

where it can be removed by hand, retract the puller. Remove the horseshoe clip and repeat this process on all the remaining anchor stakes.

Wash Down

Wash down the tooling and the unit.



Breakdown

With the engine off, disconnect the umbilical connections from the drill rack and carefully recoil the hoses and electrical cable to prevent tangles.

Disconnect the grounding cables, recoil the ground mat and ground rod, and store.

Return the drill rack to the trailer.

⚠ WARNING: Crushing Weight, if moved or operated in an unsafe manner, this equipment can crush operators or bystanders.

Roll up the ground mats and unscrew the ground rod from the earth, clean off the dirt and return to the trailer.

Fill in all potholes and excavations, erect any required barricades, and remove any barricades or other site safety equipment, which is no longer, required.

Remove the chocks holding the trailer wheels and you are now ready for the next setup.

Drilling Fluid

If the unit is not going to be used again the same day, the drilling fluid must be off-loaded and the entire fluid system flushed with clean water or antifreeze in freezing conditions.

IMPORTANT: Drilling Solution is a non-hazardous material but should be disposed of in a responsible manner. Obey all local regulations regarding disposal of drilling fluids.

See mud system operator's manual for complete details.

Chapter 9

Maintenance

Engine

The 2462 is equipped with a 4 cylinder, John Deere engine model number 4020. Refer to the engine manufacturer's Operation and Maintenance Manual for complete maintenance instructions and procedures.

Oil: Check the engine oil level daily. For the first 50hrs use only oil that meets API classification CE. The engine manufacturer recommends after the first 50 hrs the oil should be changed. Change the engine oil every 200 hours. If non-hiway diesel is used the interval should be every 100hrs. The oil must meet API classifications of CF-4 or CG-4. Refer to the engine manual to determine the proper viscosity for your local conditions.

Oil Filter: Change the engine oil filter at every oil change.

Air Cleaner: Inspect the air cleaner every 250 hours and replace every 500 hours. Check all connections for mechanical tightness. In case of leakage, replace necessary parts or gaskets if adjustment does not correct the fault. Inspect for mud caking or signs of excessive wear or damage

Fuel Filters: This unit is equipped with 2 fuel filters. The Pre-filter is located to the rear of the engine and should be replaced every 500 hours. The main Fuel Filter is located at the fuel pump and should be replaced every 1000 hours.

Fuel Tank: Check fuel level daily, the capacity of the tank is 15 Gallons (55 Liters). Fuel used in the unit should have a sulfur content of less than 0.5%

Throttle Solenoid: Engine rpm's are Low Idle 1400 rpm's, High Idle 3200 rpm's.

▲ Caution: Do not exceed the maximum operating engine speed.

Hydraulics

Hydraulic Fluid: Check hydraulic fluid level daily. The level should be slightly above half full when the oil is cold to allow for normal expansion. Replace the hydraulic oil annually. The factory fill oil is Mobil VG 32

Hydraulic Reservoir: The reservoir has an 21 gallon (80 Liter) capacity.

Hydraulic Filters: Replace the return filter in the 2462 after the first 50 hours of operation. The rotation gearbox flushing filter should be changed after the first 50hrs of operation. If the machine is equipped with this option, check the filter condition indicators weekly and replace the filter elements as required and at least once each calendar year. To check the Indicators, run the engine at high Idle with the oil at operating temperature (70° or above). A light in the control panel alerts you when the charge filters need to be replaced. **The engine will not start if the charge filters are in bypass mode**

Thrust Chains: The thrust chains will begin to stretch and loosen up after they start to wear in. Visually inspect chain tightness during pull-back to monitor chain tension. An extremely loose chain may get bunched up at the sprocket during a tough pull-back breaking the chain or damaging the thrust motor, sprockets, and bearings. Make sure both thrust chains are always adjusted equally. (See thrust chain adjustment procedure).

Thrust Assembly: The Thrust Motor is coupled to a planetary gearbox that couples to the Thrust Chain Drive Sprocket. (See Planetary Gearbox Maintenance)

Track Drive Motors: The Track Drive Motors also use a gearbox to couple to the Track Drive Sprockets. (See Planetary Gearbox Maintenance)

Maintenance

*Jet Lube is a water resistant grease. It can be used in all locations to simplify application.

Track Idler: The Track Idler is coupled directly to the Track Adjustment, there is no maintenance to this item.

Track Adjustment: The Tracks will begin to stretch and loosen up after they wear in. Visually inspect the Tracks for tightness. Loose Tracks may make popping noises, slip or stick, and possibly slip off the Drive sprocket. Remove the access cover on the side of the track frame. The grease zerk that is located inside the frame is used to tension the tracks only, and any type of grease can be used. Refer to drawing below for correct tension

Rotation Motor/Spindle: The rotation motor couples to the spindle shaft with a planetary gear box. (See Planetary Gearbox Maintenance)

Planetary Gearbox Maintenance

All of the gearboxes except the rotation gearbox use regular 80-90 weight gear lube. All rotation gearboxes without flushing kits use a synthetic gear lube such as Texaco Pinnacle EP 680. The level of all the gearboxes should be checked weekly and should be changed after the first 50 hours of operation. Thereafter, it should be changed every 500 hours or at least once every six months, whichever comes first.

To change lube in the thrust and rotation gearboxes, the drill rack needs to be in a level position. Remove the lowest plug in each gearbox to drain. On the track drives you will need to rotate the tracks until one of the two plugs is at the bottom, near the ground. When the old oil has completely drained, replace the plug and remove one plug on top of, and one near the half way fill point of the gearbox. Fill until the gear lube pours out of the half way port. On the track drive gearboxes the tacks will need to be rotated so that one of the holes is at the top of the gearbox. Be sure to dispose of old oils in a responsible manner.

Some models will have the rotation gearbox flushed with hydraulic oil. The only thing that needs to be done is checking the gauge indicator located on the top of the gearbox. This filter should be changed after the first 50 hrs of operation and then check indicator weekly and replace the filter as needed or once each year.

Saver-Sub: The purpose of the saver-sub (or sub saver) is to allow a replaceable tool joint for protecting drill pipe and the carriage spindle. Always use plenty of thread lube on the threads

every time you load another piece of drill pipe. Constantly monitor the threads on the saver sub for wear. When the sharp edges of the threads begin to show rounding or, if the shoulders of the joint will not come together, completely bottoming out, it is time to replace the saver sub. Failure to maintain the saver sub will result in costly damage to the drill pipe. Never run the drill pipe directly to the carriage spindle shaft. Always carry an extra saver-sub to allow servicing when needed. One cause of premature saver sub failure is not anchoring the drill firmly to the ground. The power anchor system should be run down all of the way and kept tight during the boring process. New operators tend to engage the threads without using the float feature on the carriage. After some operational experience the operator should be able to gently engage the saver sub with the threads of the drill pipe and that will increase thread life of both saver sub and drill pipe. Always use a high quality thread and apply it generously to each joint as the bore is being done.

Try to replace the saver sub at the end of a day to allow ample curing time for the Loctite. See Maintenance Procedures to replace the saver sub.

Carriage Roller Bearings: Maintain the carriage lubrication intervals as outlined above. Monitor the bearings for flat spots and check for free-play in the carriage daily. Failure to replace worn bearings may result in accelerated wear to the drill pipe and saver sub.

Wrench Jaws: Wrench jaws have a varying life expectancy. Depending on the manner of operation and the amount of drilling time they encounter. When the jaws fail to grip they need to be replaced. When new jaws fail to grip the wrench bodies will probably need to be replaced. (It is recommended to carry extra jaws and shear bolts.) Additional shear bolts are supplied with drill.

It is a good idea to remove the wrench cylinder covers about once a week and clean the area around the cylinders. This area gets filled with mud and thread lube that can hurt the performance of the wrenches. Again, when doing any kind of maintenance make sure that the engine is off and the key is out of the ignition.

Hydraulic System Operation:

The 2462 has a hydrostatic hydraulic system. The primary components of the system consist of 2 hydrostatic pumps and one closed center auxiliary pump, rear control box, front control panel, and the various cylinders and motors to make the unit function. The pumps are mounted directly to the rear of the diesel engine. They are variable displacement pumps (the type that only produce flow when it is needed).

The front pump (nearest the engine) supplies a 0 to 38 GPM flow, to the left track when in tram mode and to the rotation circuit when in drill mode. The center pump also supplies a 0 to 38 GPM flow to the right track when in tram mode and to the thrust circuit when in drill mode. The rear pump supplies 0 to 13 GPM to the auxiliary circuit. (Stake driver, leveling foot, wrenches, pipe loader, etc.)

WEEKLY GREASE POINTS

1	Spindle Bearing (1)	#121203	1 shot each
2	Carriage Roller Bearings (8)	#121203	1 shot each
3	Water Swivel Bearings (2)	236-7125-02	1 shot each
4	Thrust Chain Sprocket Bearings (1)	#121203	1 shot each
5	Power Anchor lead screws	#121203	Liberal coating
6	Power Anchor thrust bearings(top)	#121203	1 shot each
7	Power Anchor pivots(bottom)	#121203	1 shot each
8	Pipe handler clamp (4)	#121203	1 shot each
9			
10			
11			

Grease: #121203 is a Straightline part number any grease that meets the following criteria can be used where this part number is listed. The grease should not be less than 3% molybdenum disulfide in content. Some examples are: Mobilgrease CMP, Penzoil adhezolith EP, Castrol industrial #860/460-2, Exxon rotenex extra duty moly, Shell oil retenex cmx

Grease: #236-7125-02 is a Straightline part number any grease that meets the following criteria can be used where this part number is listed. The grease should meet ASTM D1264 spec. Some examples are: Mystic JT-6, Jet Lube Alco EP 73 plus.

2462 Lubrication and Service Interval	Daily	40 hrs	100hrs	200hrs	500hrs	1000hrs
Engine checks	X					
Check engine oil	X					
Check coolant level	X					
Check air intake systems					x	
Flush coolant system						x
Pressure test coolant system						x
Check and adjust valve clearance					x	
Check injection pump timing					x	
Check fuel injection nozzles					x	
Check belt tension and wear				x		
Service battery			x			
Check engine mounting hardware			x			
Check air cleaner restriction indicator	X					
Visual walkaround						
Engine break in oil change		x				
Engine oil change/ off hiway diesel every			x			
Engine oil change/ hiway diesel every				x		
Change engine oil filter every			x	x		
Change air filter every					x	
Change pre-filter fuel					x	
Change main fuel filter						x
Hydraulics						
Check level in sight glass	X					
Change hydraulic oil					x	
Change return hydraulic filter first time		x				
Change return hydraulic filter thereafter					x	
Charge filters first time		x				
Charge filters thereafter					x	
Rotation gearbox filter first time		x				
Rotation gearbox filter thereafter					x	
Planetary Gearboxes						
Check tram gearboxes		x				
Check thrust gearbox		x				
Change tram gearboxes first time		x				
Change tram gearboxes thereafter					x	
Change thrust gearbox first time		x				
Change thrust gearbox thereafter					x	
Grease						
Power anchor lead screws (2)	X					
Power anchor thrust bearings (2)	X					
Power anchor pivots (2)	X					
Spindle housing (2)		x				
Carriage roller bearings (8)		x				
Water swivel (2)		x				
Thrust bearing (1)		x				

Chapter 10

Maintenance Procedures

Thrust Chain Adjustment

1. Walk up to the left side of the machine and observe the bolts where the thrust chains attach to the carriage. Both of the rear attaching bolt heads should be flush against the carriage float mechanism and should not be used for adjusting the thrust chain. The front adjusting bolts should be adjusted evenly and should have adjustment left on them. If this is correct then proceed to step two.

2. With no drill pipe attached to the carriage, have an operator start the unit and with the engine at low idle, move the carriage against the front carriage stops on the drill rack. Then with the engine at low idle, engage the auto drill and adjust the thrust control knob clockwise to read 3000 psi. on the thrust pressure gauge. against the drill rack stops.

Warning: Do not reach into the drill rack to check adjustment, serious injury could result.

3. While the auto drill is engaged at 3000 psi thrust pressure, observe the thrust chains where the bracket for the rear foot pivot attaches to bottom of the drill rack.

4. If the thrust chains are adjusted properly, there should be approximately two inches between the top and bottom chain on the same side at the location described in step three. This observation can be made from the left side of the drill rack without reaching into the drill rack.

Warning: Do not reach into drill rack to check adjustment, serious injury could result.

5. If the chains are adjusted differently than described above, release the pressure from the carriage, shut off the engine and remove the key. Loosen the jam nuts at the front of the carriage and then tighten or loosen the adjusting nuts to obtain the desired spacing. **Both chains should be adjusted evenly.**

6. After correctly adjusting the chains reinstall the jam nuts to insure the bolts stay that way.

Thrust Chain Installation:

If the old chain is still in place:

1. Loosen the tension on the chain anchors on the front of the carriage.

2. Disconnect the old chain and remove. Connect the new chain to both ends of the carriage.

2. Adjust as described in the procedure above.

Thrust change lubrication:

When the owner receives delivery of the drill a silicone spray can be applied to the chains to keep them from rusting. Any lubrication can be applied to chains if the owner desires.

Straightline does not recommend any particular type of lubricant.

Saver Sub Replacement:

The saver-sub should be changed before it becomes worn to the point that the tool joint will no longer shoulder up. If the saver sub continues to be used past this wear point, the drill pipe joints can become rounded and mushroomed making replacement of all tool joints or drill pipe necessary.

Saver Sub Replacement Procedure:

Loctite adhesive is required in saver sub installation. Plan on allowing enough time for the adhesive to completely cure. It is best to replace a worn saver sub at the end of the day to allow for overnight curing.

The proper Loctite retaining compound is 680 green. Using the proper primer needed for a complete cure can accelerate the time.

Loctite 680 Green

Full Cure Without Primer = 8 hours

Full Cure With Primer "T" = 3 hours

1. Install a drill pipe, attach it to the saver-sub and run it through the pipe guide during this operation to prevent bending stress on carriage spindle.

2. The best method to break the adhesive seal is to heat the saver sub to approximately 300 degrees. At this temperature, the adhesive begins to liquefy and produce a very distinct odor.

Note: When applying heat to the saver sub, take care not to over heat it. This could transfer too much heat to the carriage spindle shaft and damage the lip seal at the carriage, as well as the spindle shaft threads.

3. Lock the saver sub into the break out wrench and reverse rotate to loosen.
4. After allowing the carriage shaft to cool, install the new saver sub using the recommended Loctite and primer (mating surfaces must be perfectly clean).
5. Use the break out wrench to lock the new saver sub onto the carriage shaft.

Wrench Service

The makeup and breakout wrenches for the 2462 use replaceable jaws to safely and securely grip the drill pipe tool joints when adding or removing drill pipe sections from the drill string. The jaws must be replaced when they wear to the point that the tool joint can no longer be securely held against rotation.

Pipe Guide Service

The 2462 uses a polyethylene pipe guide insert to lengthen the life of your drill pipe. It can easily be replaced by driving out the old and inserting a new one in its place. Replace the worn insert before it has any chance to scar the drill pipe.

Drill pipe care & preventative maintenance

Straightline drill pipe has been machined and checked with every possible inspection. However in order for the drill pipe to have maximum life a few procedures must be followed.

1. Inspect both joint members thoroughly before using. Watch for signs of jammed or misaligned threads. All joints need to be thoroughly lubricated before using the first time. Very thorough lubrication should continue each time the drill pipe is connected together, including the tooling.
2. Use only a high quality drill pipe thread lubricant. The amount of lubricant is not as important as how it is applied. Use a stiff brush to apply the thread lubricant evenly to all threads on the joint. Placing a small amount on the joint just before makeup is not adequate.
3. Stab the joints carefully – Use the float feature of the carriage in order to gently mate up the tool joints. Avoid running the carriage down with full force or unscrew the tool joint against pressure.
4. Make up the joint to the recommended torque. Tighten the tool joint to complete bypass

pressure before releasing wrench and continuing to bore.

5. Clean all foreign material off the threads before using the pipe. Excess sand or dirt will cause excessive wear on the joints.

6. If a tool joint does become damaged do not use it while boring. The damaged threads will continue to ruin all of the other threads it comes in contact with.

Power Anchor Service:

The power anchor should be lubricated before each use. If the power anchor lead screw becomes very contaminated with foreign material the lead screw should be washed down very thoroughly with high pressure water. After washing down it should be dried off with compressed air immediately. The proper grease should be applied to the screw and then run the power anchor up and down the lead screw before using the anchor system to anchor the drill.